

An alternative mechanism should also be considered¹⁸

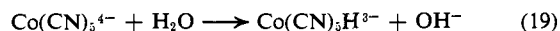
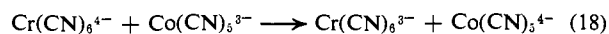

which is analogous to the mechanism proposed for the reaction of $\text{Co}(\text{CN})_5^{3-}$ with the strongly reducing e_{aq}^- .²⁵ In the present case the first step would correspond to the rate-determining step, in accord with the rate law in eq 6. The second step, eq 19, would need to be more rapid than eq 18 in order that this mechanism be consistent with the kinetic data. For eq 19, the rate constant²⁵ is $1.0 \pm 0.1 \times 10^5 \text{ sec}^{-1}$ ($t_{1/2} = 7 \mu\text{sec}$), which is certainly much faster than eq 18. Consequently, the scheme shown in eq 18 is certainly an attractive alternative.

Considering that reaction 4 occurs in solutions in which reaction 1 is being studied, the question must be raised of whether the kinetic data for reaction 1 are affected as a consequence. Given the rate constants for reaction 1 and 4, the latter reaction would be expected to cause negligible interference with the kinetic study of the first step under the concentrations used in evaluating the kinetic behavior of the first experiment, excess $\text{Co}(\text{CN})_5\text{Br}^{3-}$. This is consistent with our results on reaction 1.

The combined use of $\text{Cr}(\text{CN})_6^{4-}$ and $\text{Co}(\text{CN})_5^{3-}$ leads to hydrogenation of α, β -unsaturated molecules.

(25) (a) G. D. Venerable, E. J. Hart, and J. Halpern, *J. Amer. Chem. Soc.*, **91**, 7538 (1969); (b) G. D. Venerable and J. Halpern, *ibid.*, **93**, 2176 (1971).

Certain differences between the present case and that in which $\text{Co}(\text{CN})_5^{3-}$ is used alone should be noted, however. Most striking of these is that the latter process involves the use of *molecular hydrogen* as a reactant, the sequence of steps being the following.

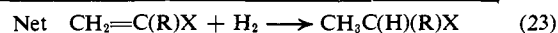
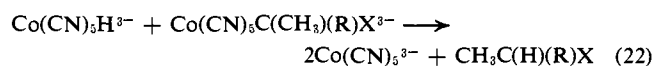
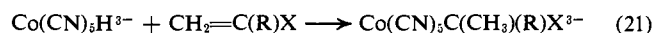
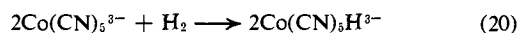

In the sequence involving $\text{Cr}(\text{CN})_6^{4-}$, however, molecular hydrogen is not used.

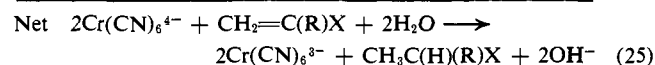
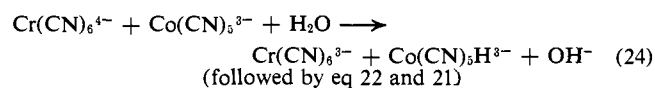

In other words, the utilization of $\text{Cr}(\text{CN})_6^{4-}$ results in its consumption during hydrogenation with the hydrogen being derived from the solvent, whereas with $\text{Co}(\text{CN})_5^{3-}$ alone, molecular hydrogen is required and is consumed during the reaction.

In the scheme utilizing $\text{Co}(\text{CN})_5^{3-}$ alone as a catalyst, the rate of hydrogenation is limited by the rate of reaction 20 which is a rather slow process.²⁴ The utilization of both metal complexes does not suffer from the same problem, as the initial step occurs very rapidly

Some Extensively Rearranged Derivatives of Sulfur Tetrafluoride, Trifluoromethylsulfur Trifluoride, and Bis(trifluoromethyl)sulfur Difluoride from Hexafluoroisopropylideneiminolithium Reactions

Richard F. Swindell^{1a} and Jean'ne M. Shreeve*^{1b}

Contribution from the Department of Chemistry,
University of Idaho, Moscow, Idaho 83843. Received February 11, 1972

Abstract: Isolation of six extensively rearranged products (I–VI) from reactions of sulfur tetrafluoride with hexafluoroisopropylideneiminolithium demonstrates that simple, metathetical reactions do not occur. A possible mechanism is proposed. Similar rearranged products (VII–IX) form from the lithium salt with CF_3SF_3 and $(\text{CF}_3)_2\text{SF}_2$. Long-range coupling of nuclei separated by ten σ bonds is observed in the ^{19}F nmr spectrum of III.

Reaction of sulfur tetrafluoride and hexafluoroisopropylideneiminolithium does not follow the previously predictable metathesis reactions observed with inorganic chlorides and fluorides.^{2–4} Instead, the generation of $(\text{CF}_3)_2\text{CFN}=\text{SF}_2$ (I) *in situ* by the action of $\text{LiN}=\text{C}(\text{CF}_3)_2$ on SF_4 results in the forma-

tion of five new compounds each of which arises directly or indirectly from attack of the lithium salt on the sulfur difluoride imide. Thus

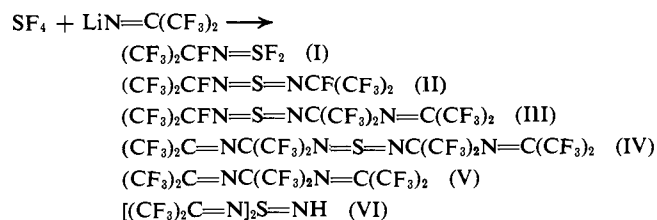

Isolation of each of the new products and subsequent

(1) (a) NDEA Graduate Fellow; (b) Alfred P. Sloan Foundation Fellow.

(2) R. F. Swindell, D. P. Babb, T. J. Ouellette, and J. M. Shreeve, *Inorg. Nucl. Chem. Lett.*, **7**, 239 (1971).

(3) R. F. Swindell, D. P. Babb, T. J. Ouellette, and J. M. Shreeve, *Inorg. Chem.*, **11**, 242 (1972).

(4) B. Cetinkaya, M. F. Lappert, and J. McMeeking, *Chem. Commun.*, 215 (1971).

reaction with the lithium salt indicates that each of the products results from a series of irreversible steps from reaction with a less highly substituted member. Similarly, reactions of CF_3SF_3 and $(\text{CF}_3)_2\text{SF}_2$ with $\text{LiN}=\text{C}(\text{CF}_3)_2$ indicate that stepwise substitution and product rearrangement occurs, producing analogs to compounds formed from reaction with SF_4 .

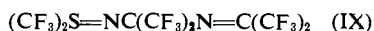
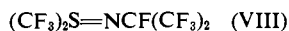
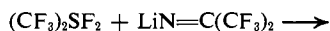
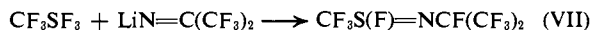

Although product analysis is consistent, yields fluctuate widely over a series of similar reaction conditions presumably due to the great differences in volatility of the liquid products which affect the ease with which further reaction occurs.

Experimental Section

Materials. SF_4 (K and K Laboratories, Inc.) and AgF_2 (Ozark-Mahoning Co.) were used without further purification. $(\text{CF}_3)_2\text{C}=\text{NH}$ was prepared according to the literature method⁵ and dried over P_2O_{10} . *n*-Butyllithium in hexane (Alfa Inorganics) was transferred into small glass bottles in an inert atmosphere box for ease in handling but otherwise was used as purchased. CF_3SF_3 ,⁶ $(\text{CF}_3)_2\text{SF}_2$,⁷ and $(\text{CF}_3)_2\text{C}=\text{NLi}$ ⁸ were prepared by literature methods. **Caution**—explosions have occurred in the preparation of $(\text{CF}_3)_2\text{C}=\text{NLi}$.

General Procedures. Gases and volatile liquids were handled in a conventional Pyrex vacuum apparatus equipped with a Heise Bourdon-tube gauge. Volatile starting materials and purified products were measured quantitatively by PVT techniques. Reactants and products of lower volatility were weighed. For gas chromatographic separations, the columns were constructed of 0.25-in. copper tubing packed with 8% SE-30 (Loenco) on Chromosorb W or 20% Kel-F oil (3M Co.) on Chromosorb P. In most cases, fractional condensation was used to effect crude separation prior to gas chromatography. Vapor-pressure studies were carried out by using the method of Kellogg and Cady⁸ or by an isoteniscope method.

Infrared spectra of volatile products were recorded with a Perkin-Elmer 457 spectrometer by using a 5-cm gas cell equipped with KBr windows. Nonvolatile liquids were run neat between NaCl disks. Fluorine-19 nmr spectra were obtained with a Varian HA-100 spectrometer by using trichlorofluoromethane as an internal standard. Mass spectra were obtained with a Perkin-Elmer Hitachi RMU-6E mass spectrometer at an ionization potential of 70 eV. Elemental analyses were performed by Beller Mikroanalytisches Laboratorium, Göttingen, Germany.

I. Reactions of SF_4 and Derivatives. Preparation of $(\text{CF}_3)_2\text{CFN}=\text{SF}_2$ (I). Sulfur tetrafluoride (4 mmol) was condensed onto $\text{LiN}=\text{C}(\text{CF}_3)_2$ (12 mmol) at -196° and warmed slowly to 25° . After 41 hr, the volatile products were separated by gas chromatography by using a 5-ft SE-30 column heated to 30° and I was obtained in 22% yield. Other products isolated were II (6%) and small amounts of III, IV, and V. Physical and spectral data for I have been reported previously.⁹

Reaction of I and $\text{LiN}=\text{C}(\text{CF}_3)_2$. $(\text{CF}_3)_2\text{CFN}=\text{SF}_2$ (2.64 mmol) was condensed onto $\text{LiN}=\text{C}(\text{CF}_3)_2$ (12 mmol) at -196° and warmed rapidly to 25° . After 20 hr, the volatile compounds were separated by trap-to-trap distillation and further purified by gas chromatography by using a 5-ft SE-30 column heated to 60° . Major products identified were V (52%), VI (24%), IV (9.5%), $(\text{CF}_3)_2\text{C}=\text{NSN}=\text{C}(\text{CF}_3)_2$ ³ (1.1%), and $(\text{CF}_3)_2\text{C}=\text{NH}$ (0.1 mmol).

Preparation of $(\text{CF}_3)_2\text{CFN}=\text{S}=\text{NCF}(\text{CF}_3)_2$ (II). $[(\text{CF}_3)_2\text{C}=\text{N}]_2\text{S}$ (22 mmol) was distilled into a 75-ml stainless steel Hoke bomb which contained AgF_2 (3 g) at -196° and allowed to warm to 25° . After

standing at 25° for 2.75 hr, $(\text{CF}_3)_2\text{CFN}=\text{S}=\text{NCF}(\text{CF}_3)_2$ (II) was obtained in almost quantitative yields. Bis(heptafluoroisopropyl)sulfur diimide is a colorless liquid with a boiling point of 106.8° obtained from the equation $\log P_{\text{Torr}} = 8.17 - 2013/T$. Vapor pressure data are as follows (T , $^\circ\text{K}$; P , Torr): 326, 100; 342.7, 200; 348.2, 250; 353, 300; 361.2, 400; 367.5, 500; 371.5, 550; 373.0, 600; 375.5, 650; 377.7, 702. The molar heat of vaporization is 9.2 kcal and the Trouton constant is 24.3 eu.

The ^{19}F nmr spectrum shows a broadened complex resonance at 145.3ϕ assigned to the equivalent isopropyl fluorines and a doublet ($J_{\text{CF}_3-\text{F}} = 4.5 \text{ Hz}$) at 79.6ϕ for the CF_3 groups. The infrared spectrum measured at 4 Torr is as follows: 1287 vs, 1263 vs, 1227 s, 1195 m, 1130 m, 1092 m, 1030 s, 995 s, 958 w, 740 sh, 732 s, 540 cm^{-1} w. Principal peaks in the mass spectrum correspond to the ions (relative intensity): M^+ (1); $\text{M} - \text{F}^+$ (5); $\text{M} - \text{F}_2^+$ (5); $\text{M} - \text{F}_3^+$ (1); $\text{M} - \text{CF}_3^+$ (22); $\text{C}_3\text{F}_9\text{N}_2\text{S}^+$ (2); $\text{C}_3\text{F}_8\text{NS}^+$ (25); $\text{C}_3\text{F}_8\text{NS}^+$ (4); $\text{C}_2\text{F}_4\text{NS}^+$ (25); $\text{C}_2\text{F}_5\text{N}^+$ (4); C_2F_4^+ (11); CF_3^+ (100); SN^+ (27).

Anal. Calcd for $\text{C}_6\text{F}_{14}\text{N}_2\text{S}$: C, 18.19; F, 66.80; N, 7.04; S, 8.05. Found: C, 18.30; F, 66.6; N, 7.02; S, 8.09.

$(\text{CF}_3)_2\text{CFN}=\text{NCF}(\text{CF}_3)_2$ is obtained in 6% yield when SF_4 (4 mmol) is reacted with $(\text{CF}_3)_2\text{C}=\text{NLi}$ (11.5 mmol).

Reaction of II and $\text{LiN}=\text{C}(\text{CF}_3)_2$. $(\text{CF}_3)_2\text{CFN}=\text{S}=\text{NCF}(\text{CF}_3)_2$ (1 mmol) was condensed onto $\text{LiN}=\text{C}(\text{CF}_3)_2$ (6.9 mmol) at -196° and warmed slowly to 25° . After 20 hr, the volatile materials were removed and identified by gas-chromatographic retention times and infrared and ^{19}F nmr spectra to be primarily IV and V, $(\text{CF}_3)_2\text{C}=\text{NH}$, and some III. No I or VI was observed.

Preparation of $(\text{CF}_3)_2\text{CFN}=\text{S}=\text{NC}(\text{CF}_3)_2\text{N}=\text{C}(\text{CF}_3)_2$ (III). SF_4 (3 mmol) was condensed onto $\text{LiN}=\text{C}(\text{CF}_3)_2$ (12 mmol) at -196° and warmed slowly to 25° . After 12.25 hr, the reaction products were separated by low-temperature distillation. $(\text{CF}_3)_2\text{CFN}=\text{S}=\text{NC}(\text{CF}_3)_2\text{N}=\text{C}(\text{CF}_3)_2$ was obtained in 2% yield after gas-chromatographic purification of the fraction trapped at -10° by using a 5-ft SE-30 column heated to 50° . Other compounds isolated were I, II, V, and VI.

The infrared spectrum is as follows: 1732 w, 1318 s, 1260 vs, 1218 vs, 1190 sh, 1095 m, 1075 w, 1012 m, 992 s, 970 sh, 942 w, 740 m, 720 sh, 685 cm^{-1} w. Principal peaks in the mass spectrum correspond to the ions (relative intensity): $\text{M} - \text{F}^+$ (1); $\text{M} - \text{CF}_3^+$ (5); $\text{M} - \text{C}_3\text{F}_8\text{N}^+$ (25); $\text{C}_3\text{F}_{11}\text{N}_2\text{S}^+$ (5); $\text{C}_6\text{H}_{12}\text{N}^+$ (27); $\text{C}_3\text{F}_8\text{N}_2\text{S}^+$ (6); $\text{C}_4\text{F}_9\text{N}_2\text{S}^+$ (5); $\text{C}_3\text{F}_{10}\text{N}^+$ (12); $\text{C}_3\text{F}_7\text{NS}^+$ (7); $\text{C}_3\text{F}_6\text{NS}^+$ (24); $\text{C}_3\text{F}_8\text{N}^+$ (5); $\text{C}_2\text{F}_4\text{NS}^+$ (13); CF_4NS^+ (6); CF_3S^+ (5); CF_3^+ (100); SN^+ (57).

Anal. Calcd for $\text{C}_9\text{F}_{19}\text{N}_3\text{S}$: C, 19.95; F, 66.50; N, 7.74; S, 5.82. Found: C, 20.05; F, 66.4; N, 7.81; S, 5.96.

Reaction of III and $\text{LiN}=\text{C}(\text{CF}_3)_2$. $(\text{CF}_3)_2\text{CFN}=\text{S}=\text{NC}(\text{CF}_3)_2\text{N}=\text{C}(\text{CF}_3)_2$ (0.3 mmol) was condensed onto $\text{LiN}=\text{C}(\text{CF}_3)_2$ (2.4 mmol) at -196° and warmed slowly to 25° . After 10 hr, the volatile compounds were removed and identified by their infrared spectra as V (0.27 mmol), $(\text{CF}_3)_2\text{C}=\text{NH}$ (trace), and IV (trace). No I, II, or VI was observed.

Preparation of $(\text{CF}_3)_2\text{C}=\text{NC}(\text{CF}_3)_2\text{N}=\text{S}=\text{NC}(\text{CF}_3)_2\text{N}=\text{C}(\text{CF}_3)_2$ (IV). After removal of the volatile compounds observed in the preparation of III, the "dry" solid residue in the reaction vessel was heated at 100° under dynamic vacuum and a nonvolatile, bright yellow liquid was collected in a vessel fitted with a rubber septum to facilitate gas chromatographic separation. The liquid was injected onto a 5-ft SE-30 column heated to 60° and pure $(\text{CF}_3)_2\text{C}=\text{NC}(\text{CF}_3)_2\text{N}=\text{S}=\text{NC}(\text{CF}_3)_2\text{N}=\text{C}(\text{CF}_3)_2$ was obtained in yields as high as 51%. Bis[2-(hexafluoroisopropylimino)hexafluoroisopropyl]sulfurdiimide is hydrolytically stable with a boiling point of 197° at 200 Torr.

The ^{19}F nmr shows a broad singlet at 66.5ϕ which is further broadened as the temperature is lowered to 10° . At 70° this becomes a sharp singlet. A second resonance at 73.5ϕ is a sharp singlet of area equal to the first and is essentially unaffected by temperature changes. The infrared spectrum (liquid, NaCl disks) is as follows: 1735 m, 1320 vs, 1160–1235 vs, 1075 s, 1010 s, 985 s, 960 s, 938 m, 791 w, 768 w, 756 s, 740 s, 690 cm^{-1} s. Principal peaks in the mass spectrum correspond to the ions (relative intensity): $\text{M} - \text{CF}_3^+$ (1); $\text{M} - \text{C}_3\text{F}_8\text{N}^+$ (9); $\text{M} - \text{C}_6\text{H}_{12}\text{N}_2^+$ (4); $\text{C}_3\text{F}_8\text{NC}_3\text{F}_6^+$ (100); $\text{C}_3\text{F}_{10}\text{N}^+$ (15); $\text{C}_3\text{F}_8\text{N}^+$ (4); $\text{C}_4\text{F}_9\text{N}^+$ (6); $\text{C}_3\text{F}_8\text{NS}^+$ (17); $\text{C}_3\text{F}_8\text{NS}^+$ (2); $\text{C}_3\text{F}_8\text{N}^+$ (2); CF_3S^+ (7); $\text{C}_3\text{F}_8\text{N}^+$ (9); CF_3^+ (90); SN^+ (9).

Anal. Calcd for $\text{C}_{12}\text{F}_{24}\text{N}_4\text{S}$: C, 20.90; F, 66.40; N, 8.14; S, 4.65. Found: C, 20.98; F, 65.2; N, 8.18; S, 4.55.

Reaction of IV and $\text{LiN}=\text{C}(\text{CF}_3)_2$. $(\text{CF}_3)_2\text{C}=\text{NC}(\text{CF}_3)_2\text{N}=\text{S}=\text{NC}(\text{CF}_3)_2\text{N}=\text{C}(\text{CF}_3)_2$ (0.59 mmol) was injected into a vessel containing $\text{LiN}=\text{C}(\text{CF}_3)_2$ (3 mmol) which had been heated to 70°

(5) W. J. Middleton and C. G. Krespan, *J. Org. Chem.*, **30**, 1398 (1965).

(6) E. W. Lawless and L. D. Harman, *Inorg. Chem.*, **7**, 391 (1968).

(7) D. T. Sauer and J. M. Shreeve, *J. Fluorine Chem.*, **1**, 1 (1971).

(8) K. B. Kellogg and G. H. Cady, *J. Amer. Chem. Soc.*, **70**, 3986 (1948).

(9) O. Glemser and S. P. von Halasz, *Chem. Ber.*, **102**, 3333 (1969).

under dynamic vacuum to remove excess $(CF_3)_2C=NH$. The vessel was warmed slowly from -196 to 25° . After standing for 1.25 hr at 25° , the only volatile product obtained was V (0.58 mmol) identified by its infrared spectrum. Then chlorine (0.9 mmol) was added to the reaction vessel and after 3 hr the only volatile product observed was $(CF_3)_2C=NCl$ (0.9 mmol). No volatile sulfur-containing product was obtained.

Preparation of $(CF_3)_2C=NC(CF_3)_2N=C(CF_3)_2$ (V). Sulfur tetrafluoride (0.96 mmol) was condensed onto $LiN=C(CF_3)_2$ (2.4 mmol) at -196° and allowed to warm rapidly to 25° . After 0.3 hr the volatile products were removed and separated by gas chromatography by using a 5-ft SE-30 column at 50° . Pure $(CF_3)_2C=NC(CF_3)_2N=C(CF_3)_2$ was obtained in 39% yield from the mixture containing I, II, IV, and VI. 2,2-[Bis(hexafluoroisopropylideneimino)]hexafluoropropane is a colorless liquid having a boiling point of 109° from the equation $\log P_{Torr} = 7.76 - 1857/T$. Vapor pressure data are as follows (T , $^\circ K$; P , Torr): 314.5, 71; 321.5, 93; 327.5, 118; 335.5, 162; 344.7, 231; 351.5, 292; 358.3, 368; 363.0, 425; 368.3, 510; 375.0, 620. The molar heat of vaporization is 8.4 kcal and the Trouton constant is 22.0 eu.

The ^{19}F nmr spectrum shows a broad resonance at 68.1ϕ assigned to the four terminal CF_3 groups. Thirteen peaks centered at 75.4ϕ are assigned to the CF_3 groups on the center carbon atom ($J_{CF_3-CF_3} = 6.2$ Hz). The peak area ratio is 2:1. The infrared spectrum (5 Torr) is as follows: 1735 m, 1320 vs, 1265 vs, 1245 vs, 1232 vs (sh), 1212 vs, 1190 m, 1090 w, 1050 m, 1000 s, 960 m, 760 w, 740 m, 722 m, 690 cm^{-1} m. Principal peaks in the mass spectrum correspond to the ions (relative intensity): $M - F^+$ (1); $M - CF_3^+$ (2); $M - C_2F_5^+$ (1); $C_3F_6NC_3F_6^+$ (18); $C_2F_4NC_3F_6^+$ (7); $C_2F_3NC_3F_6^+$ (1); $C_2F_2NC_3F_6^+$ (2); $CF_2NC_3F_6^+$ (5); $C_3F_7^+$ (3); CF_2CN^+ (2); CF_3^+ (100); $C_3N_2^+$ (1); CF_2^+ (2).

Anal. Calcd for $C_9F_{18}N_2$: C, 22.60; F, 71.51; N, 5.89. Found: C, 22.48; F, 71.4; N, 6.27.

Reaction of V and $LiN=C(CF_3)_2$. $[(CF_3)_2C=N]_2C(CF_3)_2$ (1.3 mmol) and $LiN=C(CF_3)_2$ (8 mmol) did not react after 8 hr at 25° .

Preparation of $(CF_3)_2C=NS(=NH)N=C(CF_3)_2$ (VI). $(CF_3)_3CFN=SF_2$ (2.64 mmol) was condensed onto $LiN=C(CF_3)_2$ (12 mmol) at -196° and warmed rapidly to 25° . After 20 hr, the products were separated by low-temperature distillation and the contents of the warmest trap (-40°) further purified by gas chromatography using a 5-ft SE-30 column at 60° . Bis(hexafluoroisopropylideneimino)sulfurimine was obtained in 24% yield and is a colorless, readily sublimable, crystalline solid which melts at 38.5° .

The ^{19}F nmr spectrum is a singlet at 80.3ϕ . The 1H nmr spectrum is a broad singlet at τ 6.6. The infrared spectrum is as follows: 3460 m, 1490 m, 1290 s, 1255 vs, 1240 vs, 1218 sh, 1185 s, 1020 w, 960 s, 815 w, 728 s, 710 s, 540 cm^{-1} w. Principal peaks in the mass spectrum correspond to the ions (relative intensity): $M - NH^+$ (1); $M - F^+$ (2); $C_3F_{12}N^+$ (2); $M - CF_3^+$ (25); $M - CF_4^+$ (1); $M - C_3F_6^+$ (19); $C_3F_9N^+$ (2); $C_3F_8NSNH^+$ (5); $C_3F_6NS^+$ (7); $C_3F_5NS_2^+$ (2); $C_3F_6N^+$ (3); $C_2F_4NS^+$ (2); CF_3SNH^+ (9); $C_2F_3NH^+$ (30); CF_3^+ (100); C_2FN^+ (11); SNH^+ (25); SN^+ (35).

Anal. Calcd for $C_6HF_{12}N_3S$: C, 19.20; H, 0.27; F, 60.79; N, 11.20; S, 8.54. Found: C, 18.96; H, 0.48; F, 60.9; N, 11.21; S, 8.37.

$[(CF_3)_2C=N]_2SNH$ is also obtained in much lower yields when SF_4 and $LiN=C(CF_3)_2$ react.

II. Reactions of CF_3SF_3 . Preparation of $CF_3SF=NCF(CF_3)_2$ (VII). CF_3SF_3 (7 mmol) was condensed onto $LiN=C(CF_3)_2$ (4.8 mmol) at -196° and warmed slowly to 25° . After 24 hr the products were separated by trap-to-trap distillation using baths at -48 , -78 , and -184° . Unreacted CF_3SF_3 and a small amount of $CF_3S(=O)F$ (from hydrolysis of CF_3SF_3) were recovered from the bath at -184° . Pure $CF_3SF=NCF(CF_3)_2$ was obtained in 60% yield, after purification by gas chromatography of the product which stopped in the bath at -78° , by using a 2.5-ft Kel-F column at 30° . A nonvolatile yellow liquid, which stopped at -48° and subsequently slowly solidified at 25° , could not be purified by gas chromatography.

N-Heptafluoroisopropyl-*S*-trifluoromethylmonofluorosulfurimide is a colorless liquid with a boiling point of 62.9° obtained from the equation $\log P_{Torr} = 7.84 - 1666/T$. Vapor pressure data are as follows (T , $^\circ K$; P , Torr): 301, 200; 306.5, 250; 310.7, 300; 314.7, 350; 318.2, 400; 321, 450; 324, 500; 327, 550; 328.7, 600; 332.7, 693. The molar heat of vaporization is 7.95 kcal and the Trouton constant is 23.6 eu.

The ^{19}F nmr spectrum is discussed in a later section of the paper. The infrared spectrum is as follows: 1315 m, 1295 s, 1270 vs, 1255 vs, 1198 s, 1132 vs, 1094 s, 1018 m, 988 vs, 760 w, 722 m, 678

s, 542 w, 468 w, 450 cm^{-1} m. Principal peaks in the mass spectrum correspond to the ions (relative intensity): $M - 2F^+$ (1); $M - 3F^+$ (1); $M - CF_3^+$ (12); $C_3F_7NS^+$ (2); $C_3F_6NS^+$ (11); $C_3F_5NS^+$ (1); $C_2F_4NS^+$ (12); $C_2F_3NS^+$ (2); CF_3S^+ (2); CF_3S^+ (5); $C_2F_4^+$ (3); $C_2F_2N^+$ (2); CF_3^+ (100); SF^+ (8); CF_2^+ (3); NS^+ (73).

Anal. Calcd for $C_4F_{11}NS$: C, 15.84; F, 69.0; N, 4.62; S, 10.54. Found: C, 15.94; F, 69.3; N, 4.66; S, 10.66.

III. Reactions of $(CF_3)_2SF_2$. Preparation of $(CF_3)_2S=NCF(CF_3)_2$ (VIII). $(CF_3)_2SF_2$ (5 mmol) was condensed onto $LiN=C(CF_3)_2$ (7.2 mmol) at -196° and warmed slowly to 25° . After 18.5 hr the products were separated by trap-to-trap distillation using baths at -40 , -78 , and -184° . $(CF_3)_2S=NCF(CF_3)_2$ which stopped in a bath at -40° was obtained pure in 71% yield after purification by gas chromatography using a 7-ft Kel-F column at 25° . Other products observed in the separation included small amounts of $[(CF_3)_2C=N_2]$ and $(CF_3)_2S=NC(CF_3)_2N=C(CF_3)_2$ (IX).

N-Heptafluoroisopropyl-*S*,*S*-bis(trifluoromethyl)sulfurimide is a colorless liquid with a boiling point of 89.1° obtained from the equation, $\log P_{Torr} = 7.40 - 1640/T$. Vapor pressure data are as follows (T , $^\circ K$; P , Torr): 314.2, 150; 321.7, 200; 328.0, 250; 333.2, 300; 337.7, 350; 342.2, 400; 345.5, 450; 349.7, 500; 352.0, 550; 355.0, 600; 357.7, 650; 359.7, 695. The molar heat of vaporization is 7.5 kcal and the Trouton constant is 20.7 eu.

The ^{19}F nmr spectrum contains resonances at 138, 81.2, and 64ϕ in the ratio of 1:6:6, respectively. The resonance at 138ϕ , assigned to the isopropyl fluorine, is an overlapping heptet of heptets from splitting by two CF_3 groups on carbon ($J_{F-CF_3C} = 4.7$ Hz) and two CF_3 groups on sulfur ($J_{F-CF_3S} = 1.6$ Hz). The resonance at 81.2ϕ is assigned to the CF_3 groups on carbon and is an overlapping doublet of heptets split by the isopropyl fluorine ($J_{CF_3C-F} = 4.7$ Hz) and the remaining CF_3 groups ($J_{CF_3C-CF_3S} = 1.4$ Hz). At 64ϕ , the CF_3 groups on sulfur are split by the isopropyl fluorine ($J_{CF_3S-F} = 1.6$ Hz) and the remaining two CF_3 groups ($J_{CF_3S-CF_3C} = 1.4$ Hz). The infrared spectrum is as follows: 1322 m, 1300 m, 1262 vs, 1212 s, 1138 vs, 1089 vs, 990 m, 760 w, 732 m, 700 w, and 455 cm^{-1} m. Principal peaks in the mass spectrum correspond to the ions (relative intensity): M^+ (17); $M - F^+$ (10); $M - CF_3^+$ (10); $M - CF_4^+$ (18); $M - CF_5^+$ (10); $M - C_2F_6^+$ (10); $C_3F_6NS^+$ (32); $C_3F_5NS^+$ (7); $C_2F_5^+$ (15); CF_3S^+ (45); CF_2NS^+ (5); CF_2S^+ (8); CF_3^+ (100); NS^+ (11).

Anal. Calcd for C_3F_8NS : C, 17.00; F, 69.9; N, 3.98; S, 9.08. Found: C, 16.41; F, 70.0; N, 4.12; S, 8.69.

Preparation of $(CF_3)_2S=NC(CF_3)_2N=C(CF_3)_2$ (IX). $(CF_3)_2S=NCF(CF_3)_2$ (1.35 mmol) was condensed onto $LiN=C(CF_3)_2$ (4.8 mmol) at -196° and warmed slowly to 25° . After 18 hr, the product which stopped in a bath at -30° was purified by gas chromatography using a 5-ft SE-30 column heated to 50° . Pure $(CF_3)_2S=NC(CF_3)_2N=C(CF_3)_2$ was obtained in 82% yield.

2,4,4,6-Tetrakis(trifluoromethyl)-2-thia-3,5-diaza-2,5-perfluoroheptadiene is a colorless liquid with an extrapolated boiling point of 136.6° . The equation $\log P_{Torr} = 8.21 - 2183/T$ holds for temperatures below 100° . Above this temperature, the compound decomposes to $CF_3SN=C(CF_3)_2$ and an unidentified solid. Vapor pressure data to 100° are as follows (T , $^\circ K$; P , Torr): 330.0, 40; 341.2, 65; 348.0, 90; 354.0, 111; 360.0, 140; 365.0, 170; 369.0, 198; 373.0, 232. The molar heat of vaporization is 9.8 kcal and the Trouton constant is 23.9 eu.

The ^{19}F nmr shows single sharp resonances at 73.1 and 62.7ϕ and a broad resonance of 63.8ϕ . Peaks are in the ratio 1:1:1. The resonance at 73.1ϕ is assigned to the internal CF_3 groups, the resonance at 62.7ϕ assigned to the CF_3 groups on sulfur, and the broadened resonance at 63.8ϕ assigned to the CF_3 groups adjacent to the imine moiety. The infrared spectrum is as follows: 1730 w, 1322 m, 1285 m, 1255 vs, 1232 s, 1218 s, 1168 m, 1128 s, 1085 s, 998 m, 970 w, 935 m, 754 w, 735 m, and 690 cm^{-1} m. Principal peaks in the mass spectrum correspond to the ions (relative intensity): $M - C_3F_6NS^+$ (15); $C_4F_9NS^+$ (45); $C_4F_8NS^+$ (22); $C_4F_8N^+$ (15); $C_3F_6NS^+$ (45); $C_3F_5NS^+$ (15); $C_2F_6N^+$ (22); $C_2F_4NS^+$ (2); $C_2F_3NS^+$ (6); $C_2F_5^+$ (15); $C_2F_2NS^+$ (9); CF_3S^+ (47); CF_2NS^+ (20); CF_2S^+ (9); $C_2F_2N^+$ (23); CF_3^+ (100); CFS^+ (7); SF^+ (12); CF_2^+ (18) [$M - C_2F_6^+$ (<1)].

Anal. Calcd for $C_8F_{18}N_2S$: C, 19.30; F, 68.6; N, 5.63; S, 6.43. Found: C, 19.65; F, 68.5; N, 6.08; S, 6.69.

Results and Discussion

Many examples of the preparation and reactions of the general class of compounds sulfur difluoride imides

(RN=SF₂) and sulfur diimides (RN=S=NR) have been reported recently (ref 10-23 and references cited therein), and the chemistry of the former is covered in a review on sulfur-nitrogen-fluorine compounds.²⁴ The principal method for preparing RN=SF₂ compounds utilizes reactions of nitrogen-containing species with SF₄ and the sulfur difluoride imide so formed may undergo further reaction to form sulfur diimides.

By reacting SF₄ with the lithium salt of hexafluoroisopropylideneimine in varying stoichiometries six compounds in isolable yields are formed, including three new sulfur diimides which arise from the *in situ* generation of a sulfur difluoride imide "intermediate," (CF₃)₂CFN=SF₂ (I).

I has been prepared in high yield by the reaction of

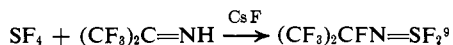

but the more highly substituted members (II-VI) have not been previously reported. Compounds I and II are formed when the ratio of LiN=C(CF₃)₂ to SF₄ is less than 4:1, but neither is observed if SF₄ is the limiting reagent. With the exception of VI, each higher member of the series can be made from reaction of its antecedent and the lithium salt, with none of the lower members being produced. Thus, adding pure II to (CF₃)₂C=NLi results in the formation of III, IV, and V with no I or VI being observed. Sulfur diimides have been shown to react with polar organic molecules to cleave the N=S bonds,²¹ which explains the formation of 0.58 mmol of V as the only volatile product observed when 0.59 mmol of IV reacts with LiN=C(CF₃)₂.

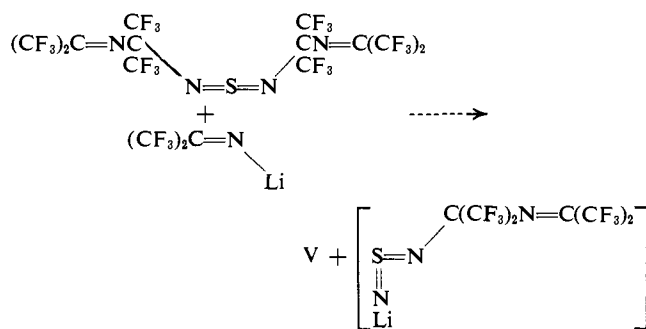

The N atom on the lithium salt is the nucleophilic site and the S=N bond is presumed to have broken and new S=N bonds formed to produce V and a proposed lithium salt which was not isolated.

- (10) S. P. von Halasz and O. Glemser, *Chem. Ber.*, **104**, 1247 (1971).
- (11) R. Mews and O. Glemser, *ibid.*, **104**, 645 (1971).
- (12) E. Niecke, O. Glemser, and H. Thamm, *ibid.*, **103**, 2864 (1970).
- (13) R. Appel and E. Lassmann, *Z. Naturforsch., B*, **26**, 73 (1971).
- (14) H. W. Roesky and H. H. Giere, *Angew. Chem., Int. Ed. Engl.*, **9**, 244 (1970).
- (15) H. W. Roesky and G. Holtschneider, *Z. Anorg. Allg. Chem.*, **378**, 168 (1970).
- (16) H. W. Roesky and H. H. Giere, *Inorg. Nucl. Chem. Lett.*, **5**, 393 (1969).
- (17) A. Haas and P. Schott, *Chem. Ber.*, **101**, 3407 (1968).
- (18) A. Haas and P. Schott, *Angew. Chem., Int. Ed. Engl.*, **6**, 370 (1967).
- (19) U. Biermann and O. Glemser, *Chem. Ber.*, **100**, 3795 (1967).
- (20) O. Glemser, S. P. von Halasz, and U. Biermann, *Inorg. Nucl. Chem. Lett.*, **4**, 591 (1968).
- (21) G. Kresze and W. Wucherpfennig, *Angew. Chem., Int. Ed. Engl.*, **6**, 149 (1967).
- (22) M. Lustig, *Inorg. Chem.*, **5**, 1317 (1966).
- (23) K. Seppelt and W. Sundermeyer, *Angew. Chem., Int. Ed. Engl.*, **8**, 771 (1969).
- (24) O. Glemser, *Endeavour*, **28**, 86 (1967).

The mechanism of formation of products I, II, and VI is difficult to deduce. Whether a simple metathetical reaction occurs between F and the (CF₃)₂C=N moiety to form a transient intermediate which rearranges by fluoride ion migration to a more electropositive center cannot be demonstrated without isolating the postulated intermediate, *i.e.*

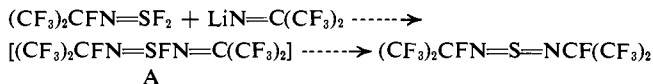

The formation of CF₃(F)S=NCF(CF₃)₂ (VII) (discussed later in this section) and the recently reported synthesis of a previously unknown aminosulfurmonofluoride imide (N=SFNR₂)²⁵ could argue for the existence of A even though the possibility of structural rearrangement of these imides is not likely. Further implicit evidence for this, or some similar intermediate, arises from the formation of [(CF₃)₂C=N]₂S=NH (VI). None of this new sulfurimine is observed in the reaction of II, III, IV, or V with the lithium salt; therefore, the precursor to the product probably arises from reaction of SF₄ or I. Since reaction of I results in greater yields of VI than does reaction of SF₄, it seems reasonable to postulate an intermediate A which can either rearrange to form II and subsequently III, IV, and V or which can itself undergo reaction with the lithium salt to form a precursor to VI (see Scheme 1).

Addition of (CF₃)₂C=NH to the solid residue remaining after pulling off the volatiles results in the formation of VI in yields as high as 24%.



Some of VI is usually observed in the volatile products before addition of (CF₃)₂C=NH. In the preparation of LiN=C(CF₃)₂, formed by adding excess (CF₃)₂C=NH to *n*-BuLi, slightly more than a 1:1 uptake of parent imine is observed which is not recovered even after pumping on the solid for several hours. When the lithium salt is heated to 70° under dynamic vacuum, excess (CF₃)₂C=NH is pulled off the solid and subsequent reaction with SF₄ produces very little VI until (CF₃)₂C=NH is added to the solid.

In a nearly analogous series of reactions, (CF₃)₂SF₂ and LiN=C(CF₃)₂ react to produce the monosubstituted rearranged compound (CF₃)₂S=NCF(CF₃)₂ (VIII) which in turn reacts readily with the lithium salt to form the disubstituted derivative (CF₃)₂S=NC(CF₃)₂N=C(CF₃)₂ (IX). Unlike IV, IX does not undergo further reaction with LiN=C(CF₃)₂ and is thermally less stable, decomposing above 100° to CF₃SN=C(CF₃)₂ and an unidentified yellow solid.

Metathesis reactions of CF₃SF₃ and LiN=C(CF₃)₂ did not proceed as did the above sulfur IV reactions. The monosubstituted product CF₃SF=NCF(CF₃)₂ was readily obtained in reasonable yields when excess CF₃SF₃ was used, but yields dropped to almost zero when CF₃SF₃ was the limiting reagent. Instead, a nonvolatile, yellow liquid was formed which could not be purified by gas chromatography and which slowly solidified at 25°. Numerous resonances were observed in the ¹⁹F nmr of the neat liquid but none which could be reasonably assigned to higher homologs of the par-

- (25) S. P. von Halasz and O. Glemser, *Chem. Ber.*, **103**, 594 (1970).

Scheme I

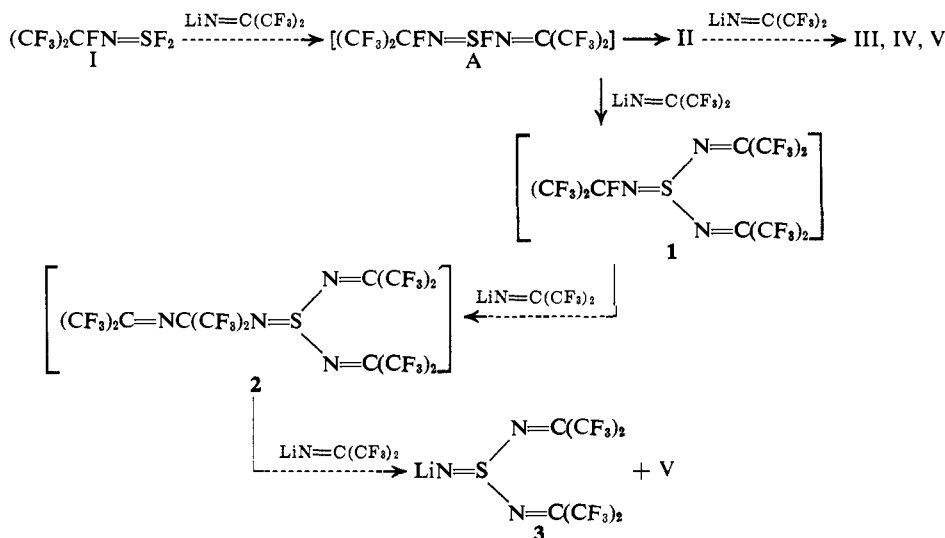

ent. When $\text{CF}_3\text{SF}=\text{NCF}(\text{CF}_3)_2$ and $\text{LiN}=\text{C}(\text{CF}_3)_2$ were reacted in varying proportions, for varying times, with or without solvent, the same intractable yellow mixture recurred. In one attempted gas-chromatographic purification, a very small amount of compound was obtained with a $\text{C}=\text{N}$ band at 1723 cm^{-1} in the infrared and four ^{19}F nmr resonances in the expected regions for the disubstituted derivative. Insufficient compound was isolated for characterization.

An interesting example of through-space coupling of remote fluorine nuclei is observed in the ^{19}F nmr spectrum of $(\text{CF}_3)_2\text{CFN}=\text{S}=\text{N}(\text{CF}_3)_2\text{N}=\text{C}(\text{CF}_3)_2$. Resonances occur at 142, 80, 73.7, and 67.6 ϕ in the ratio of 1:6:6:6. On the basis of structural analogs the assignments are given in Figure 1.²⁶ The resonance at 142 ϕ is assigned to the isopropyl fluorine and is a heptet due to splitting from the six vicinal fluorine atoms ($J_{\text{F}-\text{CF}_3} = 4.5\text{ Hz}$). A complex resonance at 80 ϕ assigned to the A CF_3 groups (see Figure 1) is resolved into a simple doublet when C is decoupled ($J_{\text{CF}_3-\text{F}} = 4.5\text{ Hz}$). C also couples with B splitting, the latter into a heptet ($J_{\text{B}-\text{C}} = 2\text{ Hz}$) which becomes a singlet at 73.6 ϕ when C is decoupled. The broadening of C arises not only from coupling to A and B but also from inversion about the C-N single bond adjacent to the imine moiety.^{2,3,27-31} Cooling the sample results in a very broad nmr signal for C at 10° , which is considerably sharpened by lowering the temperature to -40° . Heating to 80° also produces a sharper resonance for C.

Coupling of the remote ^{19}F nuclei by bonding electrons through ten σ bonds is probably negligible, the dominant coupling contributions more likely arising from nonbonded electron interaction. Through-space coupling is dependent on molecular geometry; thus the geometry of the molecule must allow for a configuration in which the terminal CF_3 groups are within at least 2.5 \AA of each other.³²⁻³⁴

(26) R. F. Swindell and J. M. Shreeve, *Inorg. Nucl. Chem. Lett.*, in press.

(27) S. Andreades, *J. Org. Chem.*, **27**, 4163 (1962).

(28) P. H. Ogden and G. V. D. Tiers, *Chem. Commun.*, 527 (1967).

(29) P. H. Ogden and R. A. Mitsch, *J. Amer. Chem. Soc.*, **89**, 3868 (1967).

(30) P. H. Ogden, *J. Org. Chem.*, **33**, 2518 (1968).

(31) P. H. Ogden and R. A. Mitsch, *J. Amer. Chem. Soc.*, **89**, 5007 (1967).

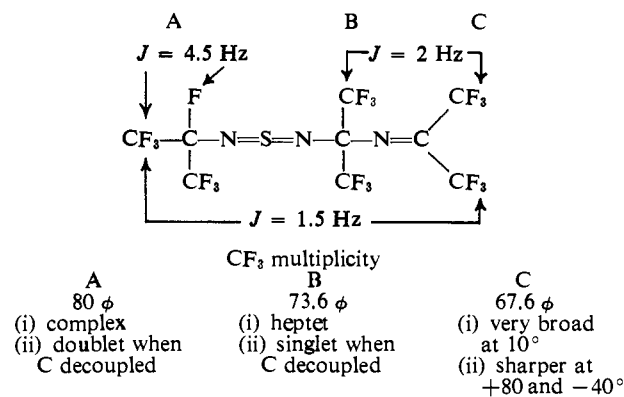
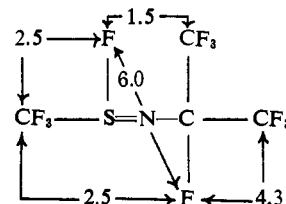

Figure 1. ^{19}F nmr of $(\text{CF}_3)_2\text{CFN}=\text{S}=\text{N}(\text{CF}_3)_2\text{N}=\text{C}(\text{CF}_3)_2$.

The ^{19}F nmr of $\text{CF}_3\text{S}(\text{F})=\text{NC}(\text{F})(\text{CF}_3)_2$ shows resonances at 145.2, 81.5, 72.9, and 11.1 ϕ in the ratio of 1:6:3:1, respectively. The following interactions are observed (coupling constants in hertz).



The resonance at 145.2 ϕ assigned to the isopropyl fluorine and the S-F resonance at 11.1 ϕ are complex multiplets each being split by all the other fluorine atoms in the molecule. The resonance at 81.5 ϕ is assigned to the CF_3 groups attached to carbon and at -45° is a doublet of doublets from splitting by the single fluorine atoms on carbon and sulfur. At 72.9 ϕ , the resonance assigned to CF_3 attached to S is split into a triplet from equal coupling to the two single fluorines. The unexpectedly large coupling of the isopropyl fluorine to CF_3-S could indicate nonbonded electron interaction but, if this is the case, the molecular geometry is such that the remote CF_3 groups do not couple

(32) L. Petrakis and C. H. Sederholm, *J. Chem. Phys.*, **35**, 1243 (1961).

(33) S. Ng and C. H. Sederholm, *ibid.*, **40**, 2090 (1964).

(34) N. Boden, J. Feeney, and L. M. Sutcliffe, *J. Chem. Soc.*, 3482 (1965).

significantly through space. Examination of molecular models renders this latter contingency unlikely. On the premise that through-bond spin-spin coupling is the predominant mechanism and from comparison of coupling constants in structural analogs, the isopropyl fluorine is assumed to couple to the two CF_3 groups on carbon more strongly than does the S-F; however,

this assignment is not unequivocal. Decoupling experiments were inconclusive.

Acknowledgments. Fluorine chemistry research at the University of Idaho is sponsored by the Office of Naval Research and the National Science Foundation. We thank Dr. R. A. De Marco for mass spectra.

Synthesis of Two Crystalline Species of the Friedel-Crafts Intermediate Antimony Pentachloride-*p*-Toluoyl Chloride. Crystal Structures of the Donor-Acceptor Complex and of the Ionic Salt

Bernard Chevrier, Jean-Marie Le Carpentier, and Raymond Weiss*

Contribution from the Institut de Chimie,¹ Université Louis Pasteur, BP 296/R8, Strasbourg, France. Received December 14, 1971

Abstract: We report for the same Friedel-Crafts intermediate the crystal structures of two well-defined adducts, the donor-acceptor complex $\text{SbCl}_5 \cdot \text{CH}_3\text{-4-C}_6\text{H}_4\text{COCl}$ and the ionic salt $[\text{SbCl}_6]^- [\text{CH}_3\text{-4-C}_6\text{H}_4\text{CO}]^+$. The first adduct (A) isolated from CCl_4 solutions crystallizes in the space group *Pbcm* with unit cell constants $a = 9.250 \pm 0.010$, $b = 22.408 \pm 0.025$, $c = 7.107 \pm 0.008$ Å; $Z = 4$. The second compound (B) isolated from CHCl_3 solutions crystallizes in the space group *P2₁/c* with unit cell constants $a = 11.840 \pm 0.009$, $b = 10.325 \pm 0.008$, $c = 12.498 \pm 0.010$ Å; $\beta = 93.90 \pm 0.20^\circ$; $Z = 4$. Intensities of 1063 (A) and 2586 (B) independent, statistically significant reflections were collected with a linear Pailred diffractometer. The structures, including positions of hydrogen atoms, were solved using Patterson and Fourier methods and refined by full-matrix least-squares calculations to conventional unweighted R_1 factors of 0.039 (A), 0.042 (B) and weighted R_2 factors of 0.047 (A), 0.056 (B). The donor-acceptor complex (A) is composed of an SbCl_5 group coordinated with the oxygen atom of the *p*-toluoyl chloride group. The Sb-O bond length is 2.253 (6) Å. The observed distortions of the octahedron SbCl_5O have been interpreted as arising from intramolecular steric effects. The ionic salt (B) consists of discrete hexachloroantimonate anions and methyl-4-phenyloxocarbenium cations. The closest interionic distances are found between the chlorine atoms of the $[\text{SbCl}_6]^-$ anions and the carbonyl carbon of the $[\text{CH}_3\text{-4-C}_6\text{H}_4\text{CO}]^+$ cations. The C-O bond length of 1.097 (9) Å is equivalent to that determined in alkyloxocarbenium ions, but the adjacent C-C bond length of 1.396 (10) Å is appreciably shorter than that generally found in alkyloxocarbenium ions. On the other hand, the positive charge of the $[\text{CH}_3\text{-4-C}_6\text{H}_4\text{CO}]^+$ cation is largely delocalized into the phenyl ring, whereas this charge is mainly localized on the carbonyl carbon atom in aliphatic oxocarbenium ions.

The presence of two functional groups in acyl halides, the carbonyl donor group and the ionizable halogen atom, suggests that two types of intermediates may intervene in the interaction of acyl halides with Lewis acid type Friedel-Crafts catalysts, *viz.* the oxocarbenium salt and the covalent donor-acceptor complex.

The evidence of stable species of both types has been demonstrated by infrared²⁻⁶ and nmr^{7,8} studies and X-ray crystallography.⁹⁻¹² Solution studies by nmr

and infrared techniques suggest also some evidence that both species of a same compound may coexist.^{7,13} Until now, however, no Friedel-Crafts intermediate has been isolated in both structural states. We report here a study of this type. It also represents the first direct structural determination of an aromatic oxocarbenium ion.

Experimental Section

The compounds are extremely sensitive to moisture and all manipulations were carried out in a drybox (VAC Model) under strictly anhydrous conditions.

The crystalline addition complexes were prepared from antimony pentachloride and *p*-toluoyl chloride using carbon tetrachloride or chloroform as solvents. Two nonidentical compounds have been isolated. The first variety (A) obtained in CCl_4 corresponds to a donor-acceptor compound; the second variety (B) isolated from CHCl_3 solutions is an ionic salt.

For X-ray diffraction studies, single crystals of the two hygroscopic addition compounds A and B were sealed in Lindeman glass capillary tubes. Precession photographs indicated that the crystal system of A was orthorhombic and the crystal system of B monoclinic. Space groups and crystal data are listed in Table I.

- (1) Laboratoire de Cristallographie associé au CNRS.
- (2) (a) B. P. Susz and J. J. Wuhrmann, *Helv. Chim. Acta*, **40**, 722 (1957); (b) *ibid.*, **40**, 971 (1957).
- (3) D. Cassimatis, P. Gagnaux, and B. P. Susz, *ibid.*, **43**, 424 (1960).
- (4) B. P. Susz and D. Cassimatis, *ibid.*, **44**, 395 (1961).
- (5) D. Cassimatis and B. P. Susz, *ibid.*, **44**, 943 (1961).
- (6) J. C. Jaccard and B. P. Susz, *ibid.*, **50**, 97 (1967).
- (7) G. A. Olah, S. J. Kuhn, W. S. Tolgyesi, and E. B. Baker, *J. Amer. Chem. Soc.*, **84**, 2733 (1962).
- (8) G. A. Olah, W. S. Tolgyesi, S. J. Kuhn, M. E. Moffatt, I. J. Bastien, and E. B. Baker, *ibid.*, **85**, 1328 (1963).
- (9) F. P. Boer, *ibid.*, **90**, 6706 (1968).
- (10) S. E. Rasmussen and N. C. Broch, *Acta Chem. Scand.*, **20**, 1351 (1966).
- (11) J. M. Le Carpentier and R. Weiss, *Acta Crystallogr.*, in press.
- (12) B. Chevrier, J. M. Le Carpentier, and R. Weiss, to be published.

- (13) D. Cook, *Can. J. Chem.*, **37**, 48 (1959).